



Discover the potential

Compact & Light Weight, Portable Dot Peen Marking Machine



Made in Turkey



ISO9001:2015

50X40MM

PR54



www.dotpeenator.com

Perpetuating Your Trade Mark...

- A Marking Area of 50X40MM
- Easy Operation By The Help Of Ergonomic Handle
- Strong Aluminium Construction
- Precise Marking By Micro Linear Guide Ways
- No-Maintenance Structure
- Stainless Steel Dust Covers
- Integrated Micro Air Regulator
- Shielded Set of 5M Cable & Air Tube
- YT188P Peen Cartridge Kit for Uneven Surface Marking
- A Push Button For Selecting Either High Speed Or Uneven Surface Marking
- Rest Unit Height Adjustment
- Second Handle For Easy Carrying
- 2,5kg Light Weight Structure
- Compact Design
- Double Guide Ways On X Axis, Single Guide Way on Y Axis

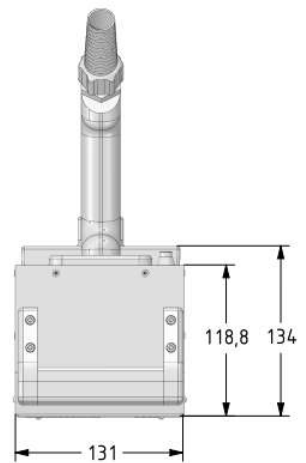
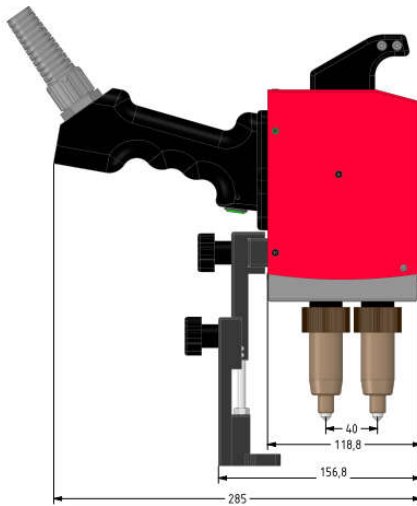



Dotpeenator™ Dot Peen Marking Machine Controllers

Specification of Dotpeenator™ SA14 Control Unit

- 7 inch TFT Color Touch Screen
- Linux Based Control Unit
- Linux Based Dotpeenator™ Marking Software
- Data Transfer
- Shift Marking
- Custom-Made Date Coding with Characters
- Create-Your-Own-Fonts Module
- Connection With A Host Computer
- Database Connection
- 3 USB Ports
- 1 RS232 Port
- Integrated I/O Port
- Connected with Keyboard & Mouse
- PLT Extended Vector Marking
- Setting Peen Tracing Points
- Linear ve Arc Scale Marking
- 2D Data Matrix Marking
- Setting a Peen Docking Point
- Setting Dot Intervals
- Circumferential Marking by an External Optional Rotary Axis
- Circumferential Letter by Letter, Word by Word, Sentence by Sentence Marking
- Selective Button for Vibro Peen Assemblies and Long-Stroke Deep Marking Peen Assemblies
- Date, Time, Shift, Julian Calendar, Day of Week, Week Number, Name of Day Marking & Requested Combination of Any
- Static Content Marking
- Vehicle Chassis Marking
- Random Code Marking
- Barcode Content Marking From a Barcode Reader
- Power Cable
- X Limit Led
- Y Limit Led
- Z Limit Led
- Power Led
- Marking Led
- USB Connection Cable

Specification of Dotpeenator™ CO9 Control Unit

- Optional 9 Pin RS232 Connection Cable
- User Friendly English Software Interface
- Marking Operations Based On SQL Queries Reading From A SQL Based Database
- Log File Follow-Up Over 365 Days
- Linear Text Marking
- 360° Circular Marking
- Arc Text Marking
- Date Marking
- Julian Date Marking
- 2D Data Matrix Code Marking
- Serial Number Marking
- Chassis Number Marking
- Alfa Numerical Character Marking
- Symbol Marking
- Random Code Marking
- Vectoral Graphics Marking
- Possibility of Showing Images of Name Tags at The Background Of The Screen For Easy Marking Content Positioning
- Peen Path Setup for Complex Work Pieces
- Adjustment of Dot Resolution Up To 0.01mm
- About 40 Special Single Line Fonts to Choose From
- Possibility of Marking All TTF Fonts
- Waiting Point Assignment for Peen Cartridge Assembly Kit
- Marking Simulation
- Reverse Marking
- Marking Upon Barcode Scanner Reading
- Alignment Of Marking Contents
- Adjustment of Valve Opening & Closing Delays
- Adjustment of Marking Speed
- Adjustment of Free Movment Speed
- Running Consecutive Marking Programs One After The Other
- Posibility of Testing Functions of Main Components
- Optional Rotary Axis for Circumferential Marking Operations
- Controlling An Additional Valve Through The I/O Port
- Pin Type Selector
- Glass Fuse



**Easy Operation
By The Help Of
Ergonomic Handle**

**Shielded Set of
5M Cable & Air Tube**



**Height-Adjustable
Aluminium Single-Leg Rest Unit**



**YT188P Peen
Cartridge Kit:
Uniquely
Designed,
18MM Uneven
Surface
Tolerating,
Special Dot
Peening Tool**

**PR54 Marking Head & Single Leg
ACROBATIC REST UNIT**